

ALYSIUM PRODUCT DOCUMENT SPECIFICATION PACK

This Document Pack is for the Specification:

A72-0418 [1] .002 **X** **-**

Which comprises of the following SubComponents:

Application Testing						
ATR 0102.001	X	Validated	19/10/2016 02:44:00	ATR 0102.001.pdf		1
ATE 2100	00	Validated	26/04/2016 03:05:00			
ATE 2103	00	Validated	26/04/2016 03:09:00			
Electrical Testing						
ETR 1901.000	X	Validated	29/07/2020 03:21:00	ETR 1901.000.pdf		1
ETE 1901	00	-				
Manufacturing Process						
LPR 0004 (RJ45 M).000	X	Validated	13/04/2023 00:49:00	LPR 0004 (RJ45 M).000.pdf		1
Label on Bag (ALY CE)	00	-				
Label on Cable (Pad Print WHT)	00	-				
GigE						
P72-0418 [1].002	X	-		P72-0418.002.pdf		3
A06-5893	02	Validated	19/05/2023 07:53:00	A06-5893 (02).pdf		1
RJ45 Unified DC (OD6.6) V2	00	-				
A99-2728	00	-				

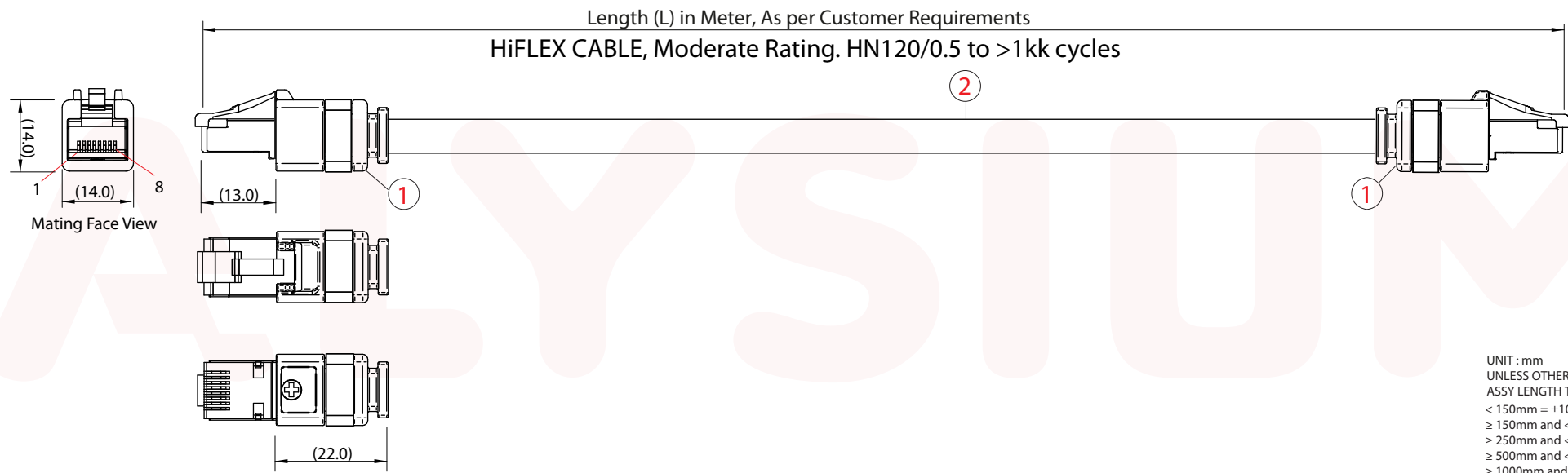

UNIT : mm
 UNLESS OTHERWISE SPECIFIED
 ASSY LENGTH TOLERANCE
 < 150mm = ±10
 ≥ 150mm and < 250mm = ±15
 ≥ 250mm and < 500mm = ±20
 ≥ 500mm and < 1000mm = ±30
 ≥ 1000mm and < 5000mm = ±50
 5000mm and above = ±100

RoHS COMPLIANT

This document is the property of Alysium-Tech. It must not be copied or otherwise disclosed without prior written consent



BILL OF MATERIALS

Item	Description
1.	A+ RJ45 Cat6A Unified DC(OD6.6) V2 Diecast Metal Shell
2.	A06-5893, [OD=6.6mm] <BLK> E357566 ALY-C UL21814 Halogen Free CAT7 4STP#26, Dual Shielded with LSZH TPU Jacket
3	Accessories (Please refer to Accessories Details):

TEST SPECIFICATION

Electrical Test (Continuity, Insulation Resistance, Conductance Test)

For Assembly Length < 20m

- 1) Voltage = 300VDC,
- 2) Insulation Resistance = 20MΩ
- 3) Conductance = 3Ω

For Assembly Length ≥ 20m

- 1) Voltage = 500VDC,
- 2) Insulation Resistance = 20MΩ
- 3) Conductance = 5Ω

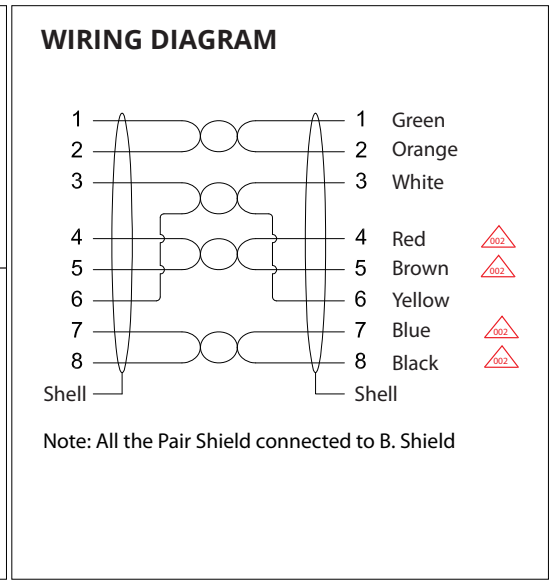

ACCESSORIES DETAILS

This Assembly/ Item ③ inclusive of accessories as per below shown:

- A) Metal Sheet Bracket (1pc)
- B) M2 Thumb Screw (2pcs)
- C) M2.6 x 2.5mm Flat Head Screw (1pc) (Pre-Installed in RJ45 connector)
- D) M2.6 x 5.0mm Flat Head Screw (1pc) (Use for install Metal Housing Bracket)
- E) Spacer (Thickness = 2 mm & 4mm) (Each 1pc)
- F) 90D Rear Hood (1pc)
- G) Hood Clip (1pc)



PLUG LENGTH & LOCKING BRACKET CUSTOMIZATION:

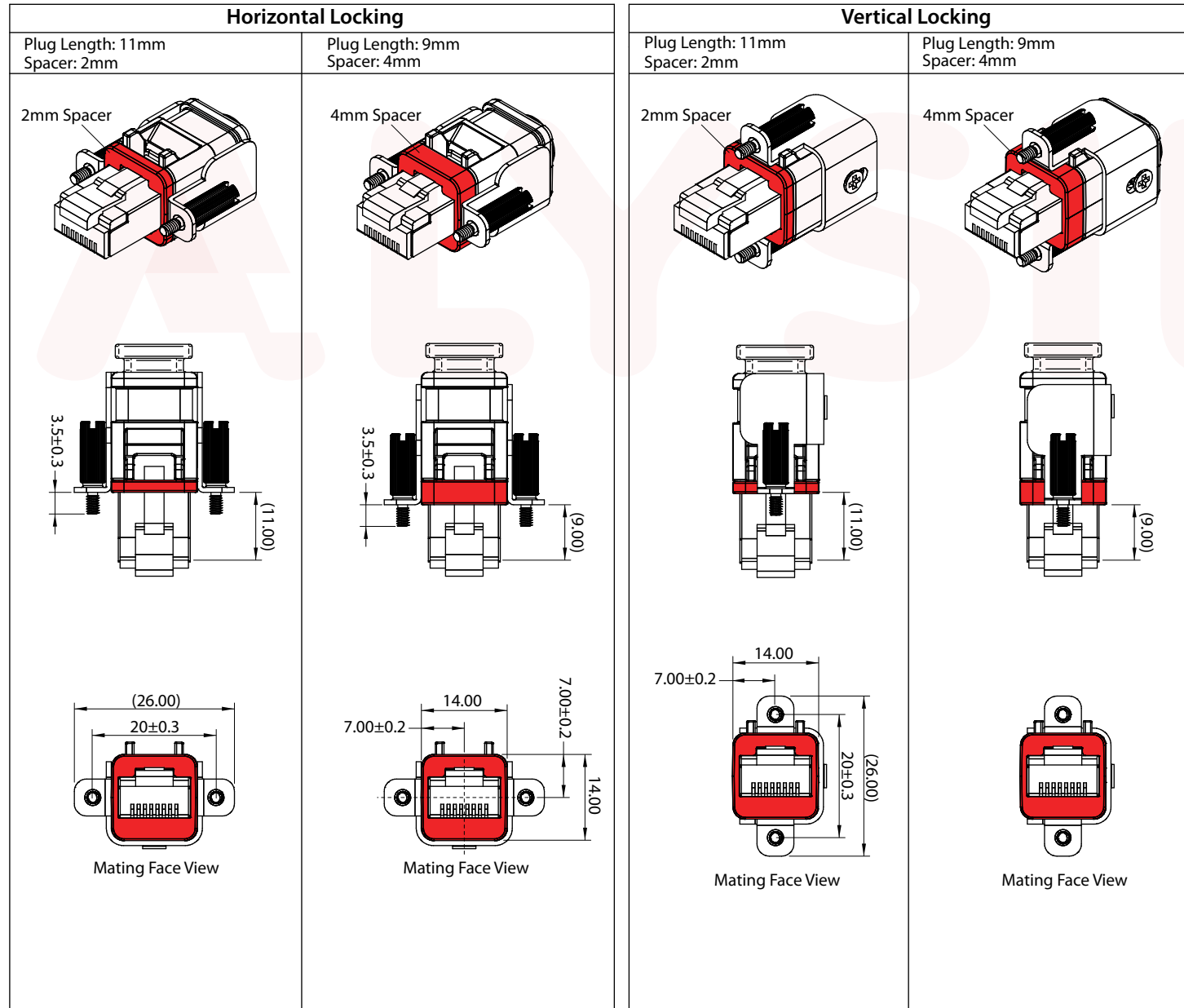

Bracket Installation Guide line

Step 1:
Remove rubber ring from the die cast body to reveal the threaded mounting hole

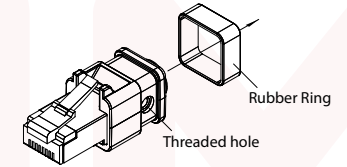

Step 2:
Determine the plug length required (9mm or 11mm) and insert the spacer to the plug from the front to depress on the latch tab

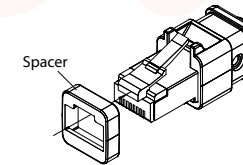

Step 3:
After spacer installation, glide the bracket from the back and fasten using M2.6 x 5.0mm screw provided

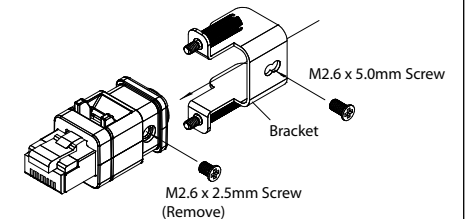

Step 4:
Customization/ installation completed
Same steps apply to horizontal bracket installation

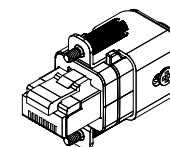



PLUG ORIENTATION CUSTOMIZATION:

A1 Direction

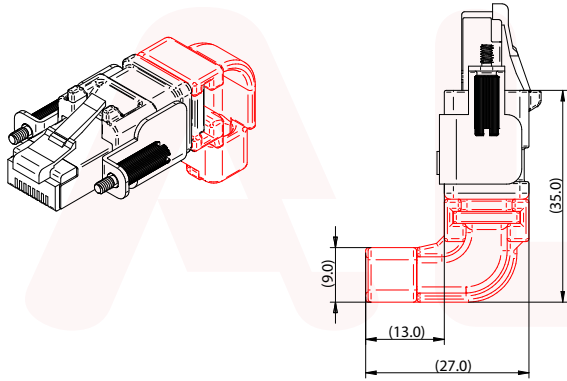

A3 Direction

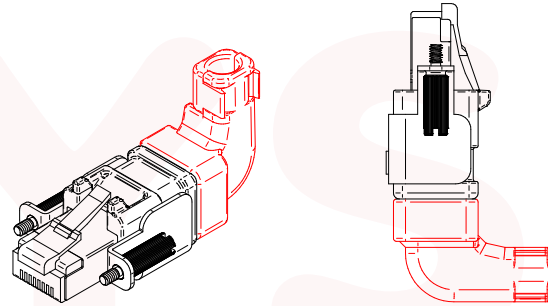

A2 Direction

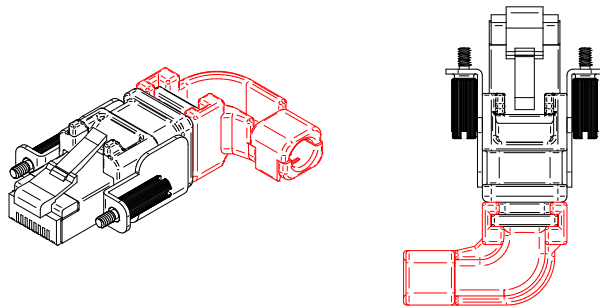

A4 Direction

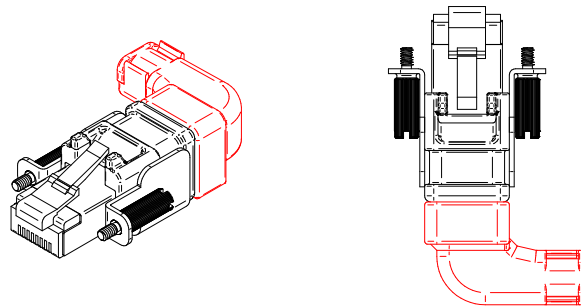

Rear Hood Installation Guide

Step1

- Decide desire connector orientation.
- Slot-in raw cable by follow trail shape (See Image 1)
- Insert and glide along Hood's groove.

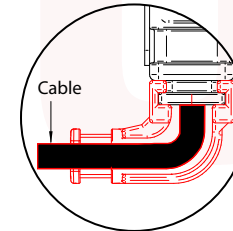
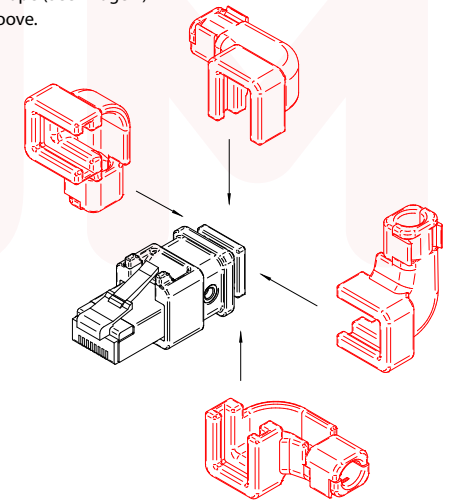
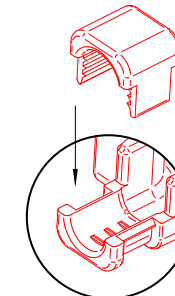

Image 1



Step 2

- Snap on by using given CLIP to secure raw cable firmly.





Heat Sealed PE Bag Packaging

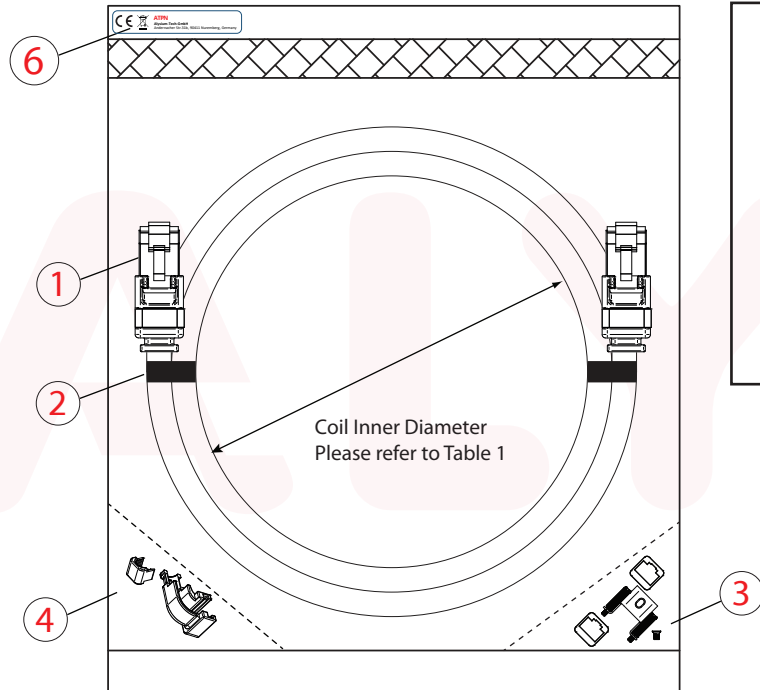

Cable Label Guideline

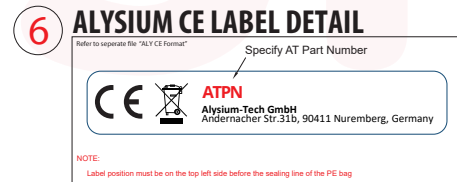
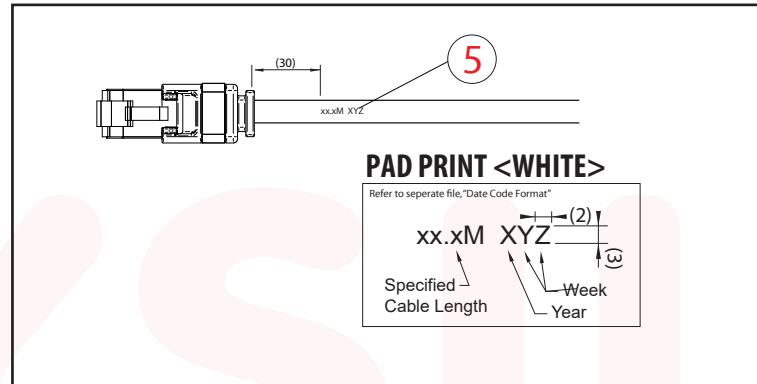

Packaging Contains

- | | |
|----------------------------------|------|
| 1) Basic Assembly | 1pc |
| 2) Magic Tie / Cable Tie | 2pcs |
| 3) Bracket Accessories | 1Set |
| --> Metal Sheet Bracket | 1pc |
| --> Thumb Screw (M2) | 2pcs |
| --> Spacer (Thickness =2mm) | 1pc |
| --> Spacer (Thickness =4mm) | 1pc |
| --> M2.6 x 5.0mm Flat Head Screw | 1pc |
| 4) 90D Rear Hood Accessories | 1Set |
| --> 90D Rear Hood | 1pc |
| --> Rear Hood Clip | 1pc |
| 5) White Pad Print | 1pc |
| 6) Label On Bag (ALY CE) | 1pc |

Table 1 : Assembly Coiling Inner Diameter
(Unless Otherwise)Specified

Type of Cable / Cable Jacket OD	Coil ID (mm)
General	250

Equipments

- 1) Fluke Model : DSX-5000 Cable Analyzer (main & remote unit);
- 2) Cat6a Adapters : DSX-PC6AS

Cat6A Test Setup

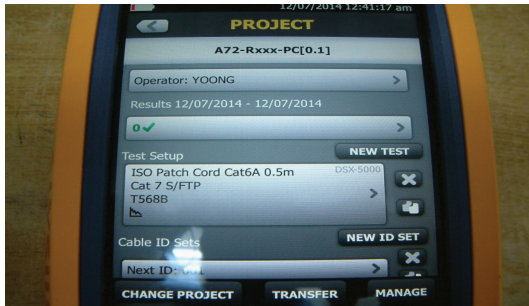

Test Setup Cat6A

Cable Type : Select Type Of Cat Cable used to build the assembly
Test Limit : ISO Patch Cord Cat6A

Testing Method



- 1) Cat6A Adapter installed on both main and remote unit of the DSX-5000
- 2) Connect RJ45 plug (assembly - both end) to the Patch Cord Adapters
- 3) Press Test Button.
- 4) Test Result will be shown on the Main Unit Of DSX-5000
- 5) Result analyzed and result saved.

Electrical Test Criteria

- 1) Open/Short circuit
- 2) Intermittent
- 3) Insulation Resistance

Hi Pot Tester Model
HB-550 (ATPN : ETE 1901)

Measurement Parameters

Voltage = 300VDC,
Insulation Resistance > 20M Ohm,
Time = 0.1s

Sampling size

100% Check

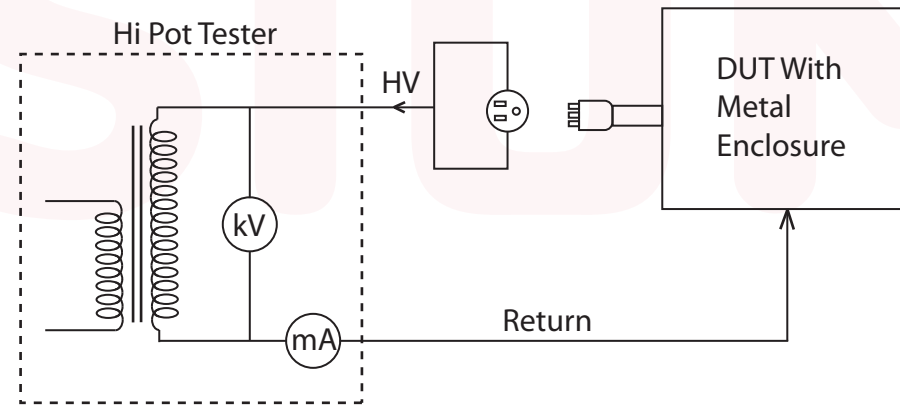

Simulated Line Leakage Diagram